



US 20140176617A1

(19) **United States**
(12) **Patent Application Publication**
JEONG et al.

(10) **Pub. No.: US 2014/0176617 A1**
(43) **Pub. Date: Jun. 26, 2014**

(54) **ORGANIC LIGHT EMITTING DISPLAY DEVICE AND DRIVING METHOD THEREOF**

(52) **U.S. Cl.**
CPC *G09G 3/2003* (2013.01)
USPC **345/690; 345/55**

(71) Applicant: **LG Display Co., Ltd., Seoul (KR)**

(72) Inventors: **Uitaek JEONG, Seoul (KR); Boeon BYEON, Gwangju (KR)**

(57) **ABSTRACT**

Disclosed is an organic light emitting display device. The organic light emitting display device includes a display panel arranged to include a plurality of unit pixels having red, green, blue, and white sub-pixels, a four-color data converter configured to convert input data of red, green, and blue of each unit pixel into data of red, green, blue, and white respectively corresponding to the red, green, blue, and white sub-pixels, and a panel driver configured to accumulate data of each of the sub-pixels at every accumulation period, store the accumulated data in a memory, decide a color correction mode for correcting a color of each unit pixel on the basis of the accumulated data of the white sub-pixel stored in the memory, drive the white sub-pixel of each unit pixel according to the decided color correction mode, and selectively drive the red, green, and blue sub-pixels.

(73) Assignee: **LG Display Co., Ltd., Seoul (KR)**

(21) Appl. No.: **14/055,531**

(22) Filed: **Oct. 16, 2013**

(30) **Foreign Application Priority Data**

Dec. 21, 2012 (KR) 10-2012-0150275

Publication Classification

(51) **Int. Cl.**
G09G 3/20 (2006.01)

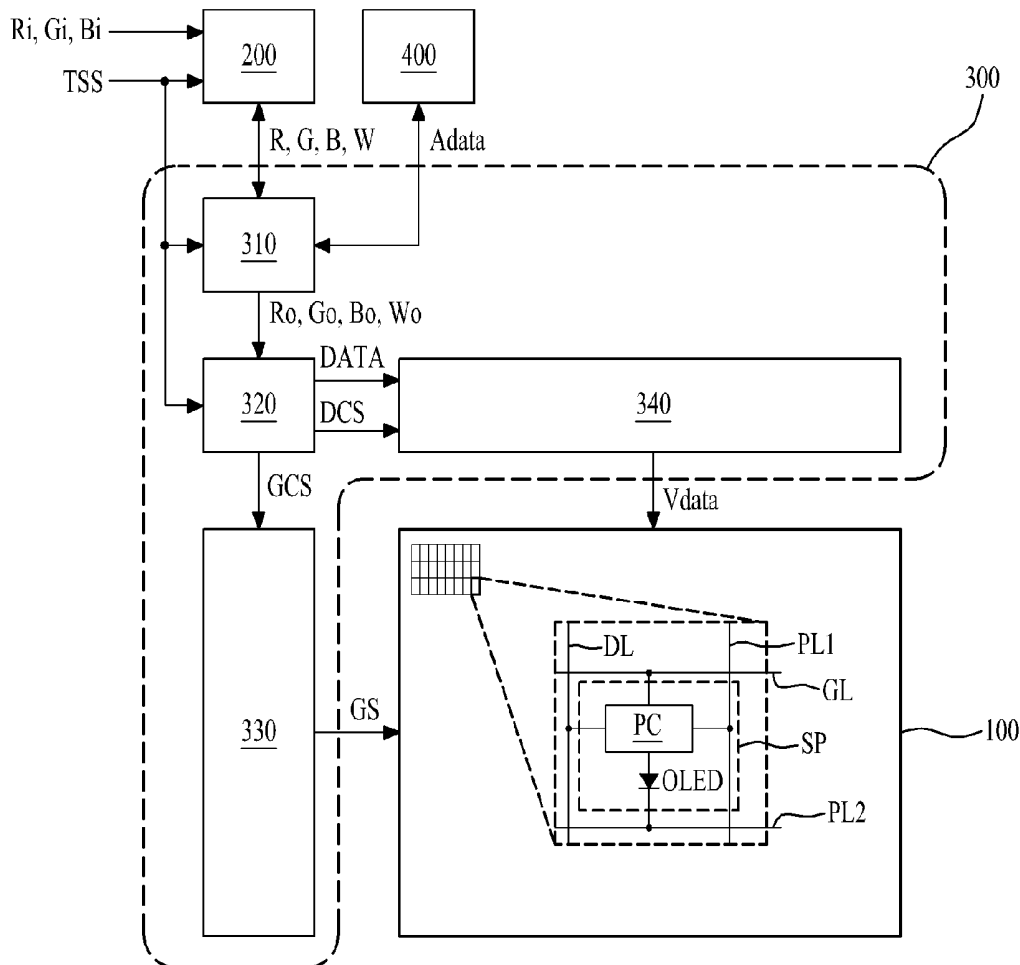

FIG. 1
Related Art

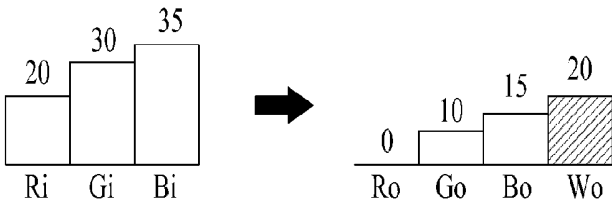

FIG. 2

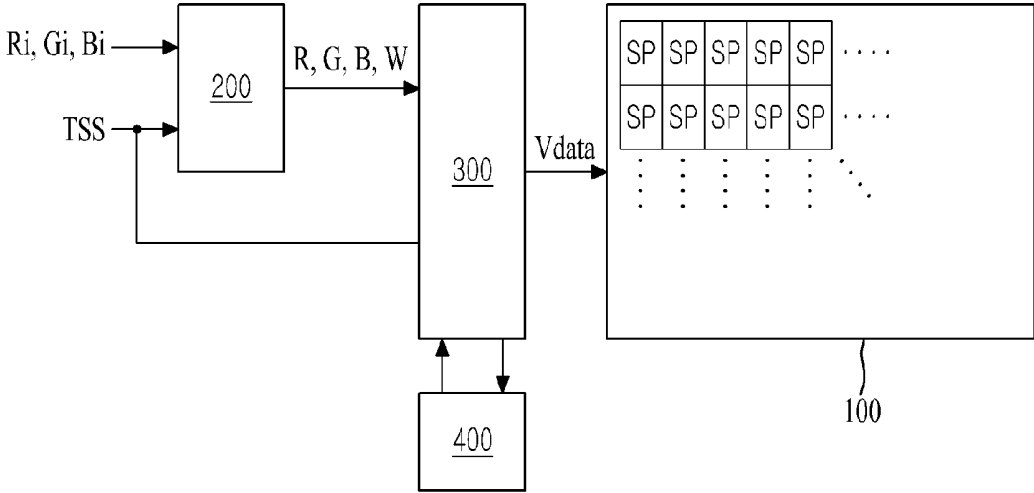

FIG. 3

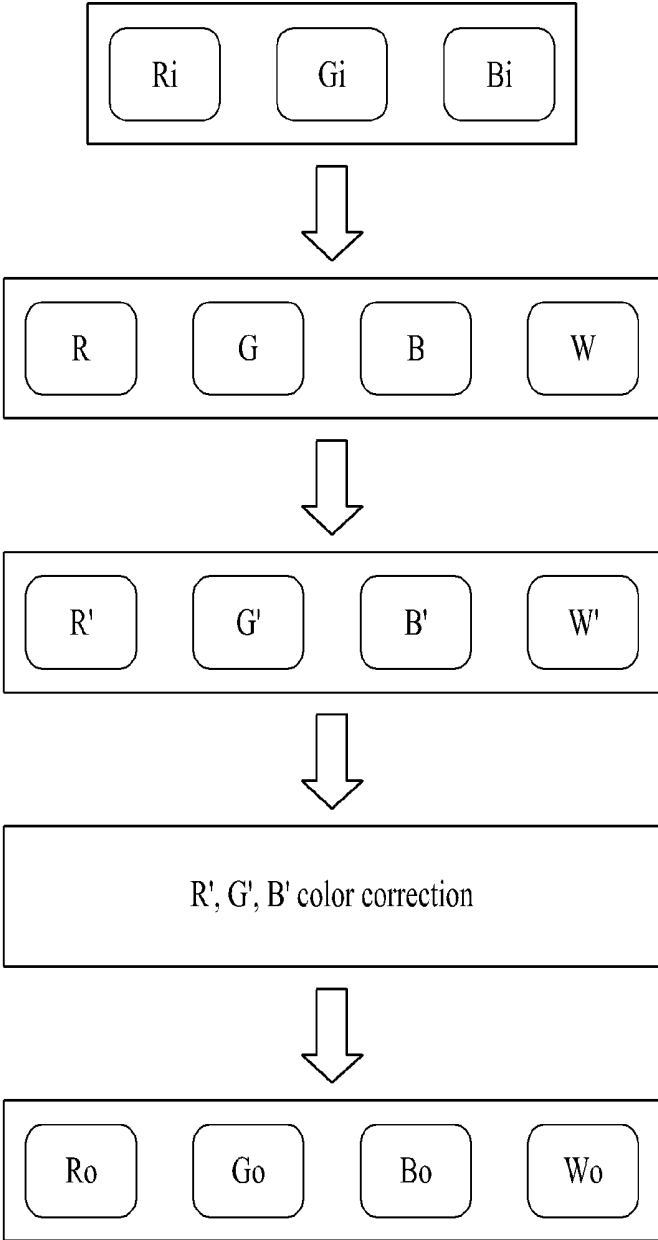

FIG. 4

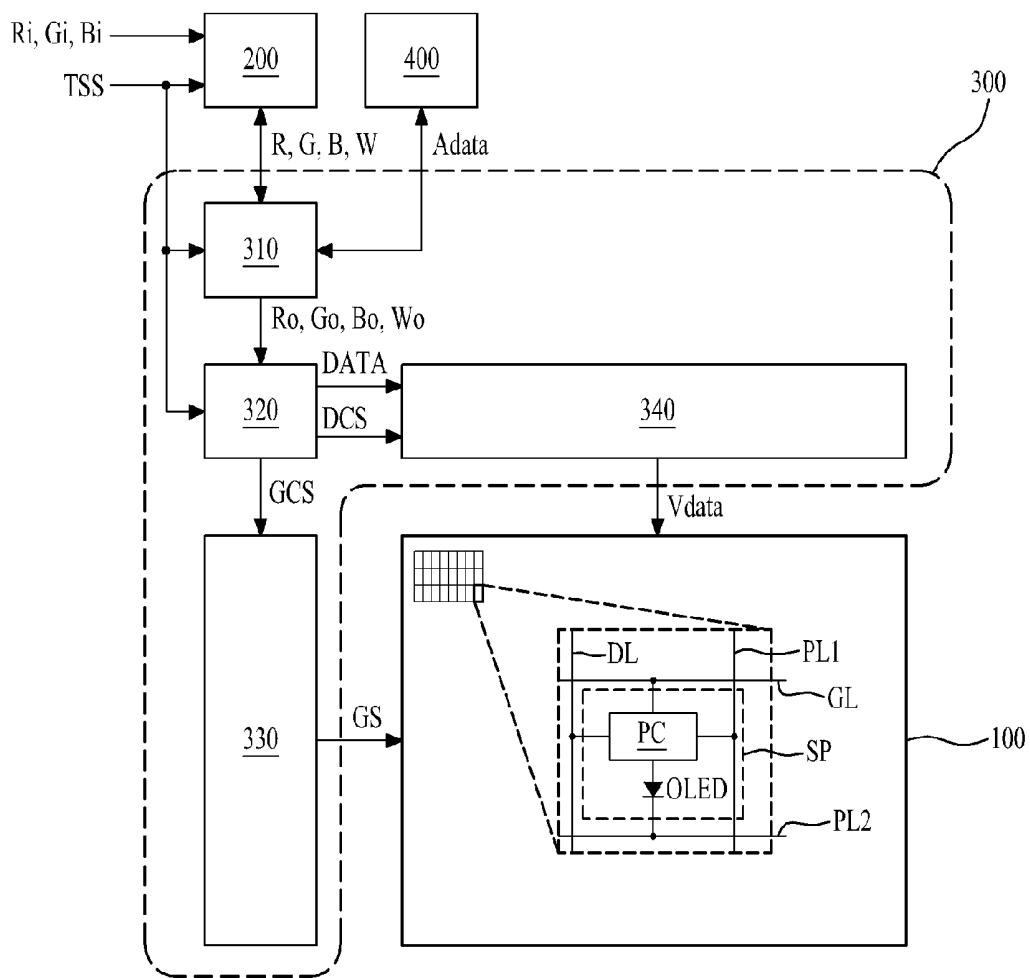

FIG. 5

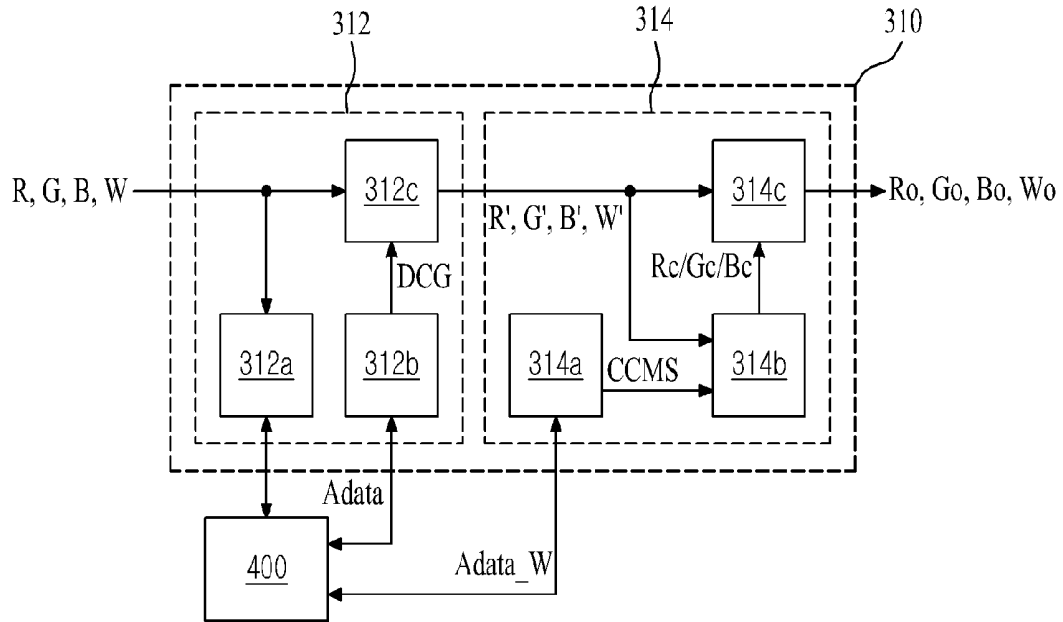

FIG. 6

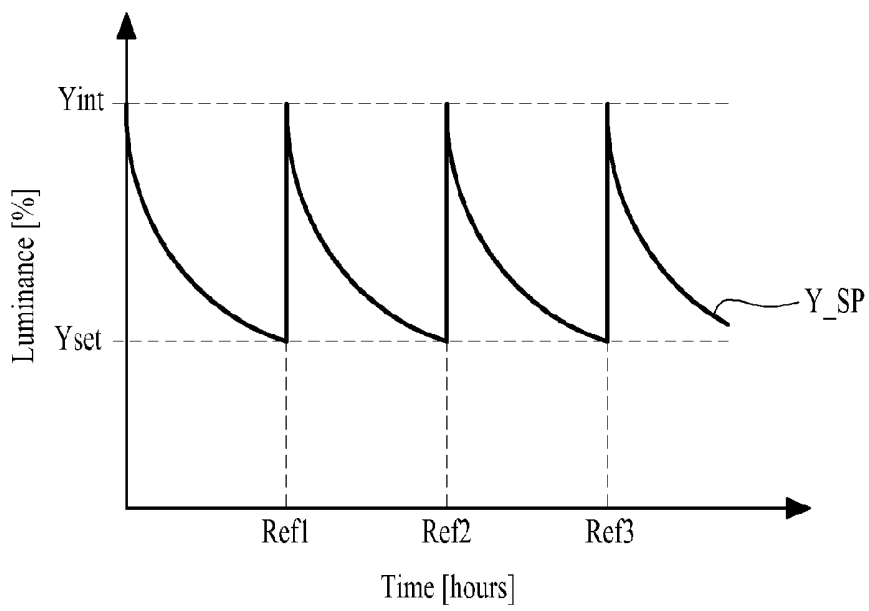

FIG. 7

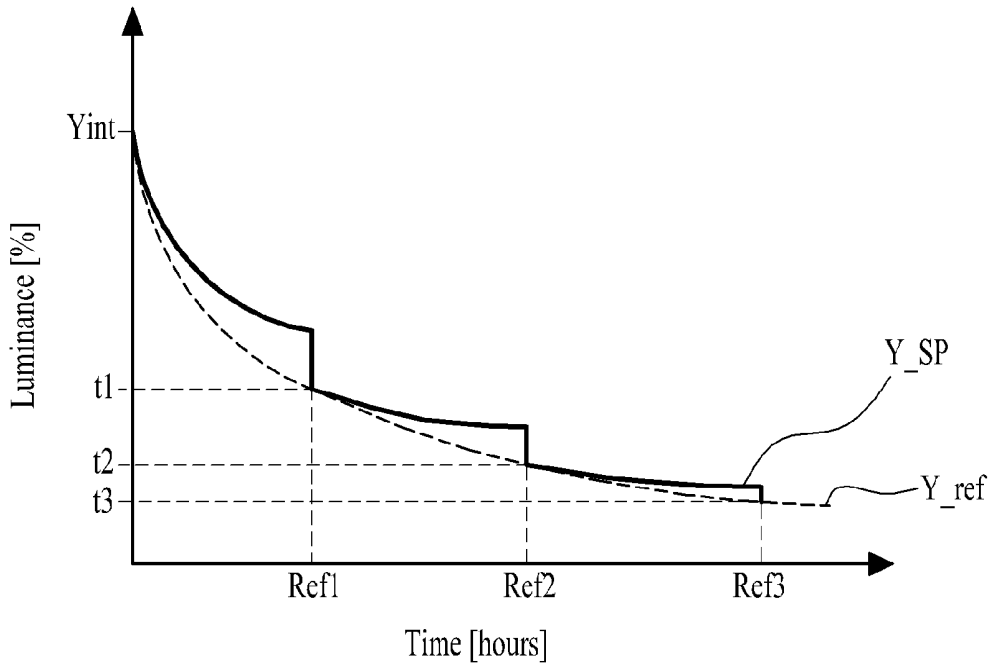
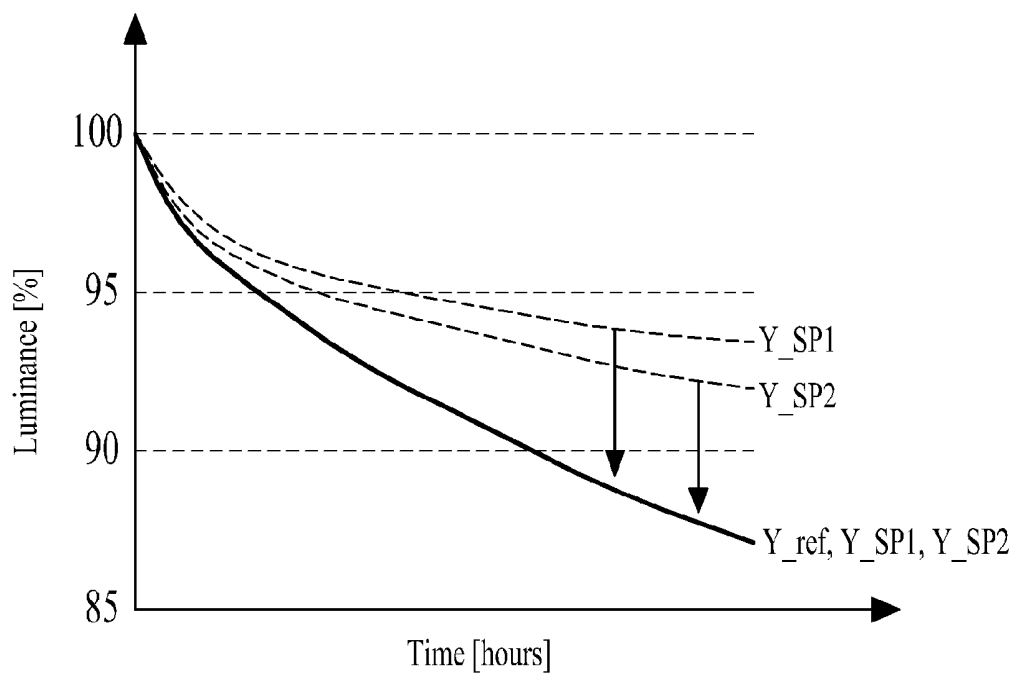

FIG. 8



**ORGANIC LIGHT EMITTING DISPLAY
DEVICE AND DRIVING METHOD THEREOF****CROSS-REFERENCE TO RELATED
APPLICATIONS**

[0001] This application claims the benefit of the Korean Patent Application No. 10-2012-0150275 filed on Dec. 21, 2012, which is hereby incorporated by reference for all purposes as if fully set forth herein.

BACKGROUND OF THE INVENTION

[0002] 1. Field of the Invention

[0003] The present invention relates to an organic light emitting display device including a plurality of white sub-pixels.

[0004] 2. Discussion of the Related Art

[0005] With the advancement of multimedia, the importance of flat panel display (FPD) devices is increasing. Therefore, various FPD devices such as liquid crystal display (LCD) devices, plasma display panel (PDP) devices, and organic light emitting display devices are being practically used. In such FPD devices, organic light emitting display devices have a fast response time, and have no limitation in a viewing angle because the organic light emitting display devices self-emit light. Accordingly, the organic light emitting display devices are attracting much attention as next generation FPD devices.

[0006] In general organic light emitting display devices, one unit pixel is configured with a red (R), green (G), and blue (B) sub-pixels, and an image of various colors is displayed through three sub-pixels.

[0007] Recently, a four-color organic light emitting display device in which a white (W) sub-pixel is added to a unit pixel is being developed to increase a luminance of the unit pixel. The four-color organic light emitting display device converts three-color input data of red, green, and blue into four-color data of red, green, blue, and white to display an image.

[0008] In driving a white color, a related art four-color organic light emitting display device continuously emits light from a white sub-pixel, and selectively emits light from two of red, green, and blue sub-pixels, thereby realizing a desired white color. That is, the related art organic light emitting display device generates, as white output data, the minimum grayscale value among input data of red, green, and blue, and subtracts the white output data from three-color input data of red, green, and blue to generate three-color output data of red, green, and blue. For example, in FIG. 1, when three-color input data R_i , G_i and B_i are composed of 20 (R_i), 30 (G_i), and 35 (B_i), the related art four-color organic light emitting display device converts the three-color input data R_i , G_i and B_i into four-color output data R_o , G_o , B_o and W_o composed of 0 (R_o), 10 (G_o), 15 (B_o), and 20 (W_o).

[0009] The above-described four-color organic light emitting display device was proposed on the assumption that color coordinates of a white sub-pixel are uniform. However, since a white organic light emitting element included in the white sub-pixel continuously emits light unlike other sub-pixels, the white organic light emitting element can be deteriorated relatively earlier than the other sub-pixels according to a material characteristic and an emission time, and a deterioration of the white organic light emitting element causes a reduction in white luminance and a change in color coordinates.

[0010] For this reason, in the related art four-color organic light emitting display device, color coordinates (CIE_x, CIE_y) are shifted depending on the deterioration of the white organic light emitting element to cause a yellowish image, and the change in color coordinates is shown like image sticking.

SUMMARY OF THE INVENTION

[0011] Accordingly, the present invention is directed to an organic light emitting display device including a plurality of white sub-pixels and a driving method thereof that substantially obviate one or more problems due to limitations and disadvantages of the related art.

[0012] An advantage of the present invention is to provide an organic light emitting display device including a plurality of white sub-pixels and a driving method thereof which can prevent a change in color coordinates due to a deterioration of a white organic light emitting element and image sticking caused by the change.

[0013] Additional advantages and features of the invention will be set forth in part in the description which follows and in part will become apparent to those having ordinary skill in the art upon examination of the following or may be learned from practice of the invention. These and other advantages of the invention may be realized and attained by the structure particularly pointed out in the written description and claims hereof as well as the appended drawings.

[0014] To achieve these and other advantages and in accordance with the purpose of the invention, as embodied and broadly described herein, there is provided an organic light emitting display device including: a display panel arranged to include a plurality of unit pixels having red, green, blue, and white sub-pixels including different organic light emitting elements; a four-color data converter configured to convert input data of red, green, and blue of each of the plurality of unit pixels into data of red, green, blue, and white respectively corresponding to the red, green, blue, and white sub-pixels of each unit pixel; and a panel driver configured to accumulate data of each of the sub-pixels supplied from the four-color data converter at every accumulation period, store the accumulated data in a memory, decide a color correction mode for correcting a color of each unit pixel on the basis of the accumulated data of the white sub-pixel stored in the memory, drive the white sub-pixel of each unit pixel according to the decided color correction mode, and selectively drive the red, green, and blue sub-pixels simultaneously with the driving of the white sub-pixel.

[0015] In another aspect of the present invention, there is provided a method of driving an organic light emitting display device, including a unit pixel having red, green, blue, and white sub-pixels including different organic light emitting elements, including: performing an A operation of converting input data of red, green, and blue of the unit pixel into data of red, green, blue, and white respectively corresponding to the red, green, blue, and white sub-pixels of the unit pixel; performing a B operation of accumulating data of each of the sub-pixels supplied from the four-color data converter at every accumulation period, and storing the accumulated data in a memory; and performing a C operation of deciding a color correction mode for correcting a color of the unit pixel on the basis of the accumulated data of the white sub-pixel stored in the memory, driving the white sub-pixel according to the decided color correction mode, and selectively driving

the red, green, and blue sub-pixels simultaneously with the driving of the white sub-pixel.

[0016] It is to be understood that both the foregoing general description and the following detailed description of the present invention are exemplary and explanatory and are intended to provide further explanation of the invention as claimed.

BRIEF DESCRIPTION OF THE DRAWINGS

[0017] The accompanying drawings, which are included to provide a further understanding of the invention and are incorporated in and constitute a part of this application, illustrate embodiments of the invention and together with the description serve to explain the principle of the invention. In the drawings:

[0018] FIG. 1 is a diagram describing a method of converting three-color data into four-color data in a related art organic light emitting display device;

[0019] FIG. 2 is a diagram describing an organic light emitting display device according to an embodiment of the present invention;

[0020] FIG. 3 is a diagram conceptually illustrating a data processing operation performed in a panel driver of FIG. 2;

[0021] FIG. 4 is a diagram describing a configuration of the organic light emitting display device according to an embodiment of the present invention;

[0022] FIG. 5 is a block diagram describing a configuration of a data modulator of FIG. 4;

[0023] FIG. 6 is a diagram describing a method of calculating a deterioration compensation gain value according to a first embodiment of the present invention;

[0024] FIG. 7 is a diagram describing a method of calculating a deterioration compensation gain value according to a second embodiment of the present invention; and

[0025] FIG. 8 is a diagram describing a method of calculating a deterioration compensation gain value according to a third embodiment of the present invention.

DETAILED DESCRIPTION OF THE ILLUSTRATED EMBODIMENTS

[0026] Reference will now be made in detail to the exemplary embodiments of the present invention, examples of which are illustrated in the accompanying drawings. Wherever possible, the same reference numbers will be used throughout the drawings to refer to the same or like parts.

[0027] The terms described in the specification should be understood as follows.

[0028] As used herein, the singular forms “a”, “an” and “the” are intended to include the plural forms as well, unless the context clearly indicates otherwise. The terms “first” and “second” are for differentiating one element from the other element, and these elements should not be limited by these terms.

[0029] It will be further understood that the terms “comprises”, “comprising”, “has”, “having”, “includes” and/or “including”, when used herein, specify the presence of stated features, integers, steps, operations, elements, and/or components, but do not preclude the presence or addition of one or more other features, integers, steps, operations, elements, components, and/or groups thereof.

[0030] The term “at least one” should be understood as including any and all combinations of one or more of the associated listed items. For example, the meaning of “at least

one of a first item, a second item, and a third item” denotes the combination of all items proposed from two or more of the first item, the second item, and the third item as well as the first item, the second item, or the third item.

[0031] Hereinafter, an organic light emitting display device and a driving method thereof according to the present invention will be described in detail with reference to the accompanying drawings.

[0032] FIG. 2 is a diagram for describing an organic light emitting display device according to an embodiment of the present invention, and FIG. 3 is a diagram conceptually illustrating a data processing operation performed in a panel driver of FIG. 2.

[0033] Referring to FIGS. 2 and 3, the organic light emitting display device according to an embodiment of the present invention includes a display panel 100, a four-color data converter 200, a panel driver 300, and a memory 400.

[0034] The display panel 100 includes a plurality of sub-pixels SP, each of which includes an organic light emitting element.

[0035] The organic light emitting element included in each sub-pixel SP emits light with a data current output from a driving transistor included in each sub-pixel SP. Here, each sub-pixel SP may be one of a red sub-pixel, a green sub-pixel, a blue sub-pixel, and a white sub-pixel. One unit pixel that displays one image includes adjacent red sub-pixel, green sub-pixel, blue sub-pixel, and white sub-pixel.

[0036] The four-color data converter 200 generates four-color data R, G, B and W of red, green, blue, and white to be respectively supplied to a red sub-pixel, a green sub-pixel, a blue sub-pixel, and a white sub-pixel, which configure one unit pixel of the display panel 100, on the basis of three-color input data Ri, Gi and Bi of red, green, and blue according to a timing sync signal (TSS) input from an external system body (not shown) or a graphics card (not shown), and supplies the four-color data R, G, B and W to the panel driver 300. For example, the four-color data converter 200 generates, as white data W, input data having the minimum grayscale value among the three-color input data Ri, Gi and Bi, subtracts the white data W from each of the three-color input data Ri, Gi and Bi to generate data R, G and B of red, green, and blue, converts the three-color input data Ri, Gi and Bi into the four-color data R, G, B and W, and supplies the four-color data R, G, B and W to the panel driver 300. Here, one of the data R, G and B of red, green, and blue has a grayscale value of 0 or black.

[0037] The panel driver 300 accumulates data R, G, B and W of the respective sub-pixels SP supplied from the four-color data converter 200 in units of a sub-pixel SP at every frame or accumulation period set as a certain period, stores the accumulated data in the memory 400, modulates the data of each sub-pixel SP on the basis of the accumulated data of each sub-pixel SP stored in the memory 400 at every frame or deterioration compensation period set as a certain period to generate modulation data R', G', B' and W' of the respective sub-pixels SP, compares a predetermined color correction reference value with the accumulated data of a white sub-pixel stored in the memory 400, and drives all or three sub-pixels including the white sub-pixel of four sub-pixels configuring each unit pixel according to the compared result.

[0038] Specifically, when the accumulated data of the white sub-pixel are less than the color correction reference value, the panel driver 300 converts the modulation data R', G', B' and W' of the respective sub-pixels SP into data voltages

Vdata, and supplies the data voltages to three sub-pixels including a white sub-pixel among red, green, blue, and white sub-pixels of each unit pixel, thereby selectively driving the three sub-pixels including the white sub-pixel of each unit pixel. In this case, in each unit pixel, two sub-pixels selected from among red, green, and blue sub-pixels and a white sub-pixel are only driven with the data voltages Vdata based on the modulation data R', G', B' and W' of the respective sub-pixels SP.

[0039] On the other hand, when the accumulated data of the white sub-pixel exceeds the color correction reference value, as illustrated in FIG. 3, the panel driver 300 color-corrects modulation data R', G' and B' of red, green, and blue with modulation data W' of a white sub-pixel for each unit pixel to generate four-color output data Ro, Go, Bo and Wo composed of white modulation data W' and color correction data Ro, Go and Bo of red, green, and blue, converts the four-color output data Ro, Go, Bo and Wo of each unit pixel into data voltages Vdata, and supplies the data voltages Vdata to the respective sub-pixels, thereby simultaneously driving four sub-pixels of each unit pixel. In this case, in each unit pixel, all sub-pixels of red, green, blue, and white are simultaneously driven with the data voltages Vdata based on the four-color output data Ro, Go, Bo and Wo, respectively.

[0040] When the white organic light emitting element included in each white sub-pixel reaches a predetermined deterioration correction time, the panel driver 300 drives all sub-pixels of each unit pixel. At this time, the panel driver 300 color-corrects and drives three-color data to be supplied to red, green, and blue sub-pixels to correct a change in color coordinates due to a deterioration of the white organic light emitting element, and thus removes image sticking caused by the change in color coordinates.

[0041] Hereinafter, the organic light emitting display device having the above-described features and a driving method thereof will be described with reference to FIGS. 4 to 8 as an example.

[0042] FIG. 4 is a diagram for describing a configuration of the organic light emitting display device according to an embodiment of the present invention, and FIG. 5 is a block diagram for describing a configuration of a data modulator of FIG. 4.

[0043] Referring to FIGS. 4 and 5, the organic light emitting display device according to an embodiment of the present invention includes the display panel 100, the four-color data converter 200, the panel driver 300, and the memory 400.

[0044] The display panel 100 includes the plurality of sub-pixels SP. The plurality of sub-pixels SP are respectively formed in a plurality of pixel areas defined by intersections between a plurality of gate lines GL and a plurality of data lines DL. A plurality of driving voltage lines PL1, which receive a driving voltage from the panel driver 300, are formed in parallel to the plurality of data lines DL in the display panel 100.

[0045] Each of the plurality of sub-pixels SP may be one of red, green, blue, and white sub-pixels. One unit pixel displaying one image may include adjacent red, green, blue, and white sub-pixels, or include red, green, and blue sub-pixels. Hereinafter, one unit pixel is assumed as including red, green, blue, and white sub-pixels.

[0046] Each of the plurality of sub-pixels SP includes the organic light emitting element OLED and a pixel circuit PC.

[0047] The organic light emitting element OLED is connected to the pixel circuit PC and a corresponding second

power line PL2, and emits light in proportion to an amount of data current supplied from the pixel circuit PC to emit certain color light. To this end, the organic light emitting element OLED includes an anode electrode (a pixel electrode) connected to the pixel circuit PC, a cathode electrode (a reflective electrode) connected to the second power line PL2, and an emission cell that is formed between the anode electrode and the cathode electrode to emit light of one of red, green, blue, and white. Here, the emission cell may be formed to have a structure of a hole transport layer/organic emission layer/electron transport layer or a structure of a hole injection layer/hole transport layer/organic emission layer/electron transport layer/electron injection layer. Further, the emission cell may further include a function layer for enhancing the emission efficiency and/or service life of the organic emission layer.

[0048] The compensation circuit using the internal compensation scheme is configured with at least one compensation transistor and at least one compensation capacitor which are formed in the pixel circuit PC. The compensation circuit using the internal compensation scheme is a scheme that stores both a data voltage and the threshold voltage of the driving transistor in the capacitor during a detection period in which the threshold voltage of the driving transistor is detected, and compensates for the threshold voltage of the driving transistor. Here, the switching transistor and the driving transistor may be an a-Si thin film transistor (TFT), a poly-Si TFT, an oxide TFT, or an organic TFT.

[0049] The switching transistor supplies the data voltage Vdata, supplied to the data line DL, to a gate of the driving transistor according to the gate-on voltage level of gate signal supplied to the gate line GL.

[0050] The driving transistor is turned on with a gate-source voltage including the data voltage Vdata supplied from the switching transistor, and controls an amount of current flowing from the driving voltage line PL1 to the organic light emitting element OLED.

[0051] The capacitor is connected between a gate and source of the driving transistor. The capacitor is charged with a difference voltage between the gate and source of the driving transistor, and then turns on the driving transistor with the charged voltage.

[0052] The numbers of transistors and capacitors configuring the above-described pixel circuit PC may be variously changed.

[0053] The four-color data converter 200 generates four-color data R, G, B and W of red, green, blue, and white to be respectively supplied to a red sub-pixel, a green sub-pixel, a blue sub-pixel, and a white sub-pixel, which configure one unit pixel of the display panel 100, on the basis of three-color input data Ri, Gi and Bi of red, green, and blue according to the timing sync signal TSS inputted from the external system body (not shown) or the graphics card (not shown), and supplies the four-color data R, G, B and W to the panel driver 300.

[0054] The panel driver 300 accumulates data R, G, B and W of the respective sub-pixels SP supplied from the four-color data converter 200 in units of a sub-pixel SP at every frame or accumulation period set as a certain period, stores the accumulated data in the memory 400, modulates the data of each sub-pixel SP on the basis of the accumulated data of each sub-pixel SP stored in the memory 400 to generate modulation data R', G', B' and W' of the respective sub-pixels SP, decides a color correction mode for three-color modulation data R', G' and B' of each unit pixel on the basis of the

accumulated data of the white sub-pixel stored in the memory 400, and drives all or three sub-pixels including the white sub-pixel of four sub-pixels configuring each unit pixel according to the color correction mode. At this time, the color correction mode may be applied at different times for each unit pixel according to the accumulated data of the white pixel of each unit pixel. To this end, the panel driver 300 includes a data modulator 310, a timing controller 320, a gate driving circuit 330, and a data driving circuit 340.

[0055] The data modulator 310, as illustrated in FIG. 5, includes a deterioration compensator 312 and a color corrector 314.

[0056] The deterioration compensator 312 accumulates data R, G, B and W of the respective sub-pixels SP supplied from the four-color data converter 200 in units of a sub-pixel SP at every frame or accumulation period set as a certain period, stores the accumulated data in the memory 400, calculates a deterioration compensation gain value DCG for each sub-pixel SP on the basis of the accumulated data of each sub-pixel SP stored in the memory 400, and modulates the data of each sub-pixel SP by using the deterioration compensation gain value DCG to generate modulation data R', G', B' and W' of the respective sub-pixels SP. To this end, the deterioration compensator 312 includes a data accumulating unit 312a, a deterioration compensation value calculating unit 312b, and a data modulating unit 312c.

[0057] The data accumulating unit 312a accumulates data R, G, B and W of the respective sub-pixels SP supplied from the four-color data converter 200 in units of a sub-pixel SP, and stores the accumulated data in the memory 400. That is, the data accumulating unit 312a reads accumulated data Adata of a corresponding sub-pixel SP corresponding to input data R, G, B and W of the respective sub-pixels SP, accumulates the data R, G, B and W to the read accumulated data Adata of the corresponding sub-pixel SP, and again stores accumulated data Adata of the corresponding sub-pixel SP accumulated until a current frame.

[0058] The deterioration compensation gain value calculating unit 312b calculates the deterioration compensation gain value DCG for compensating for a deterioration caused by a driving time (amount) of the organic light emitting element OLED included in each sub-pixel SP on the basis of the accumulated data of each sub-pixel SP stored in the memory 400 at every frame or deterioration compensation period set as a certain period.

[0059] The deterioration compensation gain value calculating unit 312b according to a first embodiment, as illustrated in FIG. 6, may calculate the deterioration compensation gain value DCG of each sub-pixel SP for increasing a luminance A of each sub-pixel SP to a predetermined initial luminance Y_{int} on the basis of the accumulated data of each sub-pixel SP stored in the memory 400. For example, the deterioration compensation gain value calculating unit 312b according to the first embodiment respectively compares the accumulated data of each sub-pixel SP with a plurality of predetermined compensation time accumulation data Ref1, Ref2 and Ref3, and when the accumulated data of each sub-pixel SP are equal to or greater than the plurality of predetermined compensation time accumulation data Ref1, Ref2 and Ref3, the deterioration compensation gain value calculating unit 312b calculates the deterioration compensation gain value DCG for increasing a luminance A of a corresponding sub-pixel SP to the predetermined initial luminance Y_{int}.

[0060] Each of the plurality of predetermined compensation time accumulation data Ref1, Ref2 and Ref3 is prediction accumulation data having a progressively increasing value so as to correspond to a predetermined luminance reduction value Y_{set} with respect to the initial luminance Y_{int} of the organic light emitting element OLED, and may be set from a relationship or a lookup table composed of prediction accumulation data for a certain luminance reduction time with respect to the initial luminance Y_{int} of the organic light emitting element OLED. Further, the deterioration compensation gain value calculating unit 312b according to the first embodiment may be configured with the lookup table to which the deterioration compensation gain value DCG having a real number value exceeding one according to accumulated data is mapped, or may be configured with an operation logic that performs an arithmetic operation for calculating the deterioration compensation gain value DCG having a real number value exceeding one according to accumulated data.

[0061] As a result, the deterioration compensation gain value calculating unit 312b according to the first embodiment repeatedly performs the above-described operation, and thus, whenever the accumulated data of each sub-pixel SP are equal to or greater than the plurality of predetermined compensation time accumulation data Ref1, Ref2 and Ref3, the deterioration compensation gain value calculating unit 312b generates the deterioration compensation gain value DCG having a real number value exceeding one.

[0062] A deterioration compensation gain value calculating unit 312b according to a second embodiment, as illustrated in FIG. 7, calculates a deterioration compensation gain value DCG of each sub-pixel SP for decreasing a luminance Y_{SP} of each sub-pixel SP to the same luminance as a luminance Y_{ref} of a sub-pixel having the most deteriorated organic light emitting element OLED on the basis of the accumulated data of each sub-pixel SP stored in the memory 400. For example, the deterioration compensation gain value calculating unit 312b according to the second embodiment extracts the maximum accumulated data having the maximum value from among the accumulated data of each sub-pixel SP stored in the memory 400, respectively compares the extracted maximum accumulated data with a plurality of predetermined compensation time accumulation data Ref1, Ref2 and Ref3, and when the maximum accumulated data are equal to or greater than the plurality of predetermined compensation time accumulation data Ref1, Ref2 and Ref3, the deterioration compensation gain value calculating unit 312b calculates the deterioration compensation gain value DCG of each sub-pixel SP on the basis of a difference value between the maximum accumulated data and the accumulated data of each sub-pixel SP.

[0063] Each of the plurality of predetermined compensation time accumulation data Ref1, Ref2 and Ref3 is prediction accumulation data corresponding to predetermined luminance reduction times t1 to t3 with respect to the initial luminance Y_{int} of the organic light emitting element OLED, and may be set from a relationship or a lookup table for calculating prediction accumulation data for a certain luminance reduction time with respect to the initial luminance Y_{int} of the organic light emitting element OLED. Further, the deterioration compensation gain value calculating unit 312b according to the second embodiment may be configured with the lookup table to which the deterioration compensation gain value DCG having a real number value less than one based on a difference value between accumulated data and the maxi-

imum accumulated data is mapped, or may be configured with an operation logic that performs an arithmetic operation for calculating the deterioration compensation gain value DCG having a real number value less than one based on the difference value between the accumulated data and the maximum accumulated data.

[0064] As a result, the deterioration compensation gain value calculating unit 312b according to the second embodiment repeatedly performs the above-described operation, and thus, whenever the deterioration compensation reference data is equal to or greater than the plurality of predetermined compensation time accumulation data Ref1, Ref2 and Ref3, the deterioration compensation gain value calculating unit 312b generates the deterioration compensation gain value DCG of each sub-pixel SP having a real number value less than one according to a difference value between the deterioration compensation reference data and the accumulated data of the sub-pixel SP, and performs adjustment in order for the luminance Y_{SP} of each sub-pixel SP to become equal to a luminance Y_{ref} of a reference sub-pixel SP.

[0065] A deterioration compensation gain value calculating unit 312b according to a second embodiment, as illustrated in FIG. 8, extracts the maximum accumulated data having the maximum value from among accumulated data of all sub-pixels SP stored in the memory 400 at every deterioration compensation time to set the maximum accumulated data to reference accumulated data, calculates an accumulation difference value between accumulated data of the respective sub-pixels SP with respect to the reference accumulated data, and calculates a deterioration compensation gain value DCG of each sub-pixel SP according to the calculated accumulation difference value of the respective sub-pixels SP. Here, the deterioration compensation gain value DCG of each sub-pixel SP is set such that luminance Y_{SP1} and Y_{SP2} of a sub-pixel having the accumulation difference value decreases to a luminance Y_{ref} of a sub-pixel having the maximum accumulated data, and for example, the deterioration compensation gain value DCG of each sub-pixel SP may be set to a real number value less than one exceeding zero. The deterioration compensation gain value DCG of each sub-pixel SP is differently calculated according to the accumulation difference value of the respective sub-pixels SP, and is updated to a new value by the above-described calculating operation at every deterioration compensation time.

[0066] The deterioration compensation gain value calculating unit 312b may calculate the deterioration compensation gain value DCG of each sub-pixel SP by using various algorithms in addition to the above-described method of calculating the deterioration compensation gain value DCG.

[0067] Referring again to FIGS. 4 and 5, the data modulating unit 312c modulates data R, G, B and W of the respective sub-pixels SP on the basis of the deterioration compensation gain value DCG of each sub-pixel SP supplied from the deterioration compensation gain value calculating unit 312b to generate modulation data R' , G' , B' and W' of the respective sub-pixels SP. For example, the data modulating unit 312c may multiply the data R, G, B and W of the respective sub-pixels SP by a corresponding deterioration compensation gain value DCG to generate the modulation data R' , G' , B' and W' of the respective sub-pixels SP, or may generate the modulation data R' , G' , B' and W' through other arithmetic operations without being limited thereto.

[0068] The color corrector 314 decides a color correction mode for three-color modulation data R' , G' and B' of each

unit pixel on the basis of the accumulated data of a white sub-pixel stored in the memory 400, and generates four-color correction data R_o , G_o , B_o and W_o of each unit pixel for driving all or three sub-pixels including the white sub-pixel of four sub-pixels configuring each unit pixel according to the color correction mode. To this end, the color corrector 314 includes a color correction mode deciding unit 314a, a three-color correction value generating unit 314a, and a data correcting unit 413c.

[0069] The color correction mode deciding unit 314a decides a color correction mode for three-color modulation data R' , G' and B' of each unit pixel on the basis of the accumulated data of the white sub-pixel stored in the memory 400, and supplies a color correction mode signal CCMS having a first or second logic level to the three-color correction value generating unit 314b. For example, when accumulated data $Adata_W$ of each white sub-pixel are less than a predetermined white deterioration reference value, the color correction mode deciding unit 314a generates the color correction mode signal CCMS having the first logic level. On the other hand, when the accumulated data $Adata_W$ of each white sub-pixel are equal to or greater than the predetermined white deterioration reference value, the color correction mode deciding unit 314a generates the color correction mode signal CCMS having the second logic level. Here, the white deterioration reference value may be set to prediction accumulation data in which a luminance of the white sub-pixel corresponds to a certain luminance reduction time with respect to an initial luminance. That is, the white deterioration reference value may be set to experimental white accumulated data at a time when a yellowish image occurs because color coordinates (CIE x , CIE y) are shifted due to a deterioration of the white organic light emitting element of the white sub-pixel.

[0070] The three-color correction value generating unit 314b generates three-color correction values R_c , G_c and B_c of each unit pixel on the basis of the color correction mode signal CCMS having the first or second logic level supplied from the color correction mode deciding unit 314a, and supplies the three-color correction values R_c , G_c and B_c to the data correcting unit 314c.

[0071] When the color correction mode signal CCMS having the first logic level is supplied from the color correction mode deciding unit 314a, the three-color correction value generating unit 314b generates the three-color correction values R_c , G_c and B_c having a value of 0 of each unit pixel, and supplies the three-color correction values R_c , G_c and B_c to the data correcting unit 314c.

[0072] When the color correction mode signal CCMS having the second logic level is supplied from the color correction mode deciding unit 314a, the three-color correction value generating unit 314b generates three-color correction values R_c , G_c and B_c for correcting a color of each unit pixel on the basis of the modulation data R' , G' , B' and W' of each unit pixel supplied from the deterioration compensator 312, and supplies the three-color correction values R_c , G_c and B_c to the data correcting unit 314c. For example, the three-color correction value generating unit 314b calculates a color ratio value of red, green, and blue based on the white modulation data W' of each unit pixel, for each unit pixel. At this time, the three-color correction value generating unit 314b may generate the color ratio value of red, green, and blue to be in correspondence with a grayscale value of the white modulation data W' with reference to a lookup table. Here, the color

ratio value of red, green, and blue is set based on the grayscale value of the white modulation data W' with respect to predetermined color coordinates (CIE_x, CIE_y) of a reference white color, and is mapped to the lookup table through previous experiment. Then, the three-color correction value generating unit **314b** generates the three-color correction values R_c , G_c and B_c of each unit pixel according to the color ratio value of red, green, and blue of each unit pixel and a predetermined white target luminance. For example, the three-color correction value generating unit **314b** may multiply the color ratio value of red, green, and blue and the white target luminance to generate the three-color correction values R_c , G_c and B_c having a real number value exceeding zero of each unit pixel.

[0073] The data correcting unit **314c** corrects the modulation data R' , G' , B' and W' of each unit pixel supplied from the deterioration compensator **312** according to the three-color correction values R_c , G_c and B_c of each unit pixel supplied from the three-color correction value generating unit **314b** to generate four-color correction data R_o , G_o , B_o and W_o for driving three sub-pixels including the white sub-pixel or four sub-pixels for each unit pixel, and supplies the four-color correction data R_o , G_o , B_o and W_o to the timing controller **320**. That is, the data correcting unit **314c** may add the modulation data R' , G' and B' of red, green, and blue of each unit pixel and the three-color correction values R_c , G_c and B_c corresponding thereto to generate the four-color correction data R_o , G_o , B_o and W_o . Therefore, one of the modulation data R' , G' and B' of red, green, and blue of each unit pixel has a grayscale value or color correction value R_c , G_c or B_c of 0 according to the above-described color correction mode.

[0074] Specifically, when there is no color correction mode described above, the data correcting unit **314c** adds the modulation data R' , G' and B' of red, green, and blue of each unit pixel and the three-color correction values R_c , G_c and B_c of 0 to generate the four-color correction data R_o , G_o , B_o and W_o . Therefore, in the three-color correction data R_o , G_o and B_o of each unit pixel, the three-color modulation data R' , G' and B' from the deterioration corrector **312** are applied as-is, and thus, one of the three-color correction data R_o , G_o and B_o of each unit pixel has a grayscale value of 0.

[0075] On the other hand, in the above-described color correction mode, the data correcting unit **314c** adds the modulation data R' , G' and B' of red, green, and blue of each unit pixel and the three-color correction values R_c , G_c and B_c having a real number value exceeding zero to generate the four-color correction data R_o , G_o , B_o and W_o . Therefore, in the three-color correction data R_o , G_o and B_o of each unit pixel, the three-color correction values R_c , G_c and B_c are respectively added to the three-color modulation data R' , G' and B' from the deterioration corrector **312**, and thus, all of the three-color correction data R_o , G_o and B_o of each unit pixel has a grayscale value exceeding zero.

[0076] Referring again to FIG. 4, the timing controller **320** controls a driving timing of each of the gate driving circuit **330** and data driving circuit **340** according to the timing sync signal TSS inputted from the external system body (not shown) or the graphics card (not shown). That is, the timing controller **320** generates a gate control signal GCS and a data control signal DCS on the basis of the timing sync signal TSS that includes a vertical sync signal, a horizontal sync signal, a data enable signal, and a dot clock. The timing controller **320** controls the driving timing of the gate driving circuit **330** by using the gate control signal GCS, and in synchronization

with this, controls the driving timing of the data driving circuit **340** by using the data control signal DCS.

[0077] Moreover, the timing controller **320** aligns the correction data R_o , G_o , B_o and W_o of each unit pixel SP, supplied from the data modulator **310**, to pixel data DATA so as to properly match a pixel arrangement structure of the display panel **100**, and supplies the aligned pixel data DATA to the data driving circuit **340** on the basis of a specific interface type.

[0078] The timing controller **320** may include the data modulator **310**. In this case, the data modulator **310** may be built into the timing controller **320**, which may be built into the data modulator in the form of programs or logics.

[0079] The gate driving circuit **330** generates a gate signal GS corresponding to a display order of images on the basis of the gate control signal GCS supplied from the timing controller **320**, and supplies the gate signal GS to a corresponding gate line GL. The gate driving circuit **330** may be provided in the forms of integrated circuits (ICs), or may be disposed directly on a substrate of the display panel **100** in a process of forming a transistor of each sub-pixel SP and connected to one side or both sides of each of the plurality of gate lines GL.

[0080] The data driving circuit **340** receives the pixel data DATA and the data control signal DCS from the timing controller **320**, and receives a plurality of reference gamma voltages from an external reference gamma voltage supplier (not shown). The data driving circuit **340** converts the pixel data DATA into an analog data voltages V_{data} by using the plurality of reference gamma voltages according to the data control signal DCS, and supplies each of the data voltages V_{data} to a data line DL of a corresponding sub-pixel SP. Therefore, each unit pixel formed in the display panel **100** emits light with a data current based on the data voltage V_{data} supplied to each sub-pixels SP, thereby displaying a certain image. At this time, in each unit pixel, only three sub-pixels including a white sub-pixel among red, green, and blue sub-pixels may be driven, or four sub-pixels may all be driven, according to the above-described color correction mode. The data driving circuit **340** may be provided in the forms of integrated circuits (ICs), and connected to one side or both sides of each of the plurality of data lines DL.

[0081] As described above, the organic light emitting display device and the driving method thereof compensate for the deterioration of the organic light emitting element on the basis of accumulated data of each sub-pixel, and selectively drive two or all of the red, green, and blue sub-pixels of each unit pixel according to the color correction mode based on accumulated data of the white sub-pixel of each unit pixel, thus preventing a change in color coordinates and a yellowish image due to the deterioration of the white organic light emitting element. Accordingly, image sticking caused by the change in color coordinates can be prevented.

[0082] It will be apparent to those skilled in the art that various modifications and variations can be made in the present invention without departing from the spirit or scope of the inventions. Thus, it is intended that the present invention covers the modifications and variations of this invention provided they come within the scope of the appended claims and their equivalents.

What is claimed is:

1. An organic light emitting display device comprising: a display panel arranged to include a plurality of unit pixels having red, green, blue, and white sub-pixels comprising different organic light emitting elements;

- a four-color data converter configured to convert input data of red, green, and blue of each of the plurality of unit pixels into data of red, green, blue, and white respectively corresponding to the red, green, blue, and white sub-pixels of each unit pixel; and
- a panel driver configured to accumulate data of each of the sub-pixels supplied from the four-color data converter at every accumulation period, store the accumulated data in a memory, decide a color correction mode for correcting a color of each unit pixel on the basis of the accumulated data of the white sub-pixel stored in the memory, drive the white sub-pixel of each unit pixel according to the decided color correction mode, and selectively drive the red, green, and blue sub-pixels simultaneously with the driving of the white sub-pixel.
2. The organic light emitting display device of claim 1, wherein,
- when in the color correction mode, the panel driver simultaneously drives all of the red, green, blue, and white sub-pixels of each unit pixel, and
- when not in the color correction mode, the panel driver simultaneously drives two of the red, green, and blue sub-pixels of each unit pixel and a white sub-pixel.
3. The organic light emitting display device of claim 1, wherein the panel driver calculates a deterioration compensation gain value of each sub-pixel for compensating for a deterioration of the organic light emitting element of each sub-pixel on the basis of the accumulated data of each sub-pixel, and modulates the converted data of each sub-pixel according to the deterioration compensation gain value to further generate modulation data of each sub-pixel.
4. The organic light emitting display device of claim 3, wherein the panel driver comprises a data modulator, the data modulator comprising:
- a deterioration compensator configured to calculate a deterioration compensation gain value of each sub-pixel on the basis of the accumulated data of each sub-pixel, and modulate data of each sub-pixel to generate the modulation data of each sub-pixel; and
- a color corrector configured to decide the color correction mode for each unit pixel on the basis of the accumulated data of the white sub-pixel, selectively color-correct the modulation data of red, green, and blue of each unit pixel according to the decided color correction mode, drive the white sub-pixel of each unit pixel, and generate correction data of red, green, blue, and white of each unit pixel for selectively driving the red, green, and blue sub-pixels simultaneously with the driving of the white sub-pixel.
5. The organic light emitting display device of claim 4, wherein the color corrector comprises:
- a color correction mode deciding unit configured to compare the accumulated data of the white sub-pixel with a predetermined white deterioration reference value to generate a first or second color correction mode signal;
- a three-color correction value generating unit configured to generate color correction values of red, green, and blue having a value of 0 when a color correction mode signal having a first logic level is supplied from the color correction mode deciding unit, and when a color correction mode signal having a second logic level is supplied from the color correction mode deciding unit, generate color correction values of red, green, and blue having a real number value exceeding zero on the basis of the white modulation data of each unit pixel; and
- a data correcting unit configured to color-correct the modulation data of red, green, and blue of each unit pixel according to the color correction values of red, green, and blue supplied from the three-color correction value generating unit according to the color correction mode signal to generate correction data of red, green, blue, and white of each unit pixel.
6. A method of driving an organic light emitting display device, including a unit pixel that includes red, green, blue, and white sub-pixels having different organic light emitting elements, the method comprising:
- performing an A operation of converting input data of red, green, and blue of the unit pixel into data of red, green, blue, and white respectively corresponding to the red, green, blue, and white sub-pixels of the unit pixel;
- performing a B operation of accumulating data of each of the sub-pixels supplied from the four-color data converter at every accumulation period, and storing the accumulated data in a memory; and
- performing a C operation of deciding a color correction mode for correcting a color of the unit pixel on the basis of the accumulated data of the white sub-pixel stored in the memory, driving the white sub-pixel according to the decided color correction mode, and selectively driving the red, green, and blue sub-pixels simultaneously with the driving of the white sub-pixel.
7. The method of claim 6, wherein the C operation comprises:
- when there is color correction mode, simultaneously driving all of the red, green, blue, and white sub-pixels; and
- when there is no color correction mode, simultaneously driving two of the red, green, and blue sub-pixels and a white sub-pixel.
8. The method of claim 6, further comprising calculating a deterioration compensation gain value of each sub-pixel for compensating for a deterioration of the organic light emitting element of each sub-pixel on the basis of the accumulated data of each sub-pixel, and modulating the converted data of each sub-pixel according to the deterioration compensation gain value to further generate modulation data of each sub-pixel.
9. The method of claim 8, wherein the C operation comprises:
- performing a C1 operation of comparing the accumulated data of the white sub-pixel with a predetermined white deterioration reference value to generate a first or second color correction mode signal for deciding the color correction mode according to the compared result; and
- performing a C2 operation of selectively color-correcting the modulation data of the red, green, and blue sub-pixels according to the first or second color correction mode signal, driving the white sub-pixel, and generating correction data of red, green, blue, and white for selectively driving the red, green, and blue sub-pixels simultaneously with the driving of the white sub-pixel.
10. The method of claim 9, wherein the C2 operation comprises:
- generating color correction values of red, green, and blue having a value of 0 according to the color correction mode signal having a first logic level, or generating color correction values of red, green, and blue having a real number value exceeding zero on the basis of the white

modulation data of the unit pixel according to the color correction mode signal having a second logic level; and reflecting the color correction values of red, green, and blue respectively corresponding to the modulation data of red, green, and blue to generate the correction data of red, green, blue, and white.

* * * * *

专利名称(译)	有机发光显示装置及其驱动方法		
公开(公告)号	US20140176617A1	公开(公告)日	2014-06-26
申请号	US14/055531	申请日	2013-10-16
[标]申请(专利权)人(译)	乐金显示有限公司		
申请(专利权)人(译)	LG DISPLAY CO., LTD.		
当前申请(专利权)人(译)	LG DISPLAY CO., LTD.		
[标]发明人	JEONG UITAEK BYEON BOEON		
发明人	JEONG, UITAEK BYEON, BOEON		
IPC分类号	G09G3/20		
CPC分类号	G09G3/2003 G09G3/3225 G09G2300/0452 G09G2320/0285 G09G2320/048 G09G2320/0666 G09G2340/06 H01L27/3213		
优先权	1020120150275 2012-12-21 KR		
其他公开文献	US9478156		
外部链接	Espacenet USPTO		

摘要(译)

公开了一种有机发光显示装置。有机发光显示装置包括：显示面板，被配置为包括具有红色，绿色，蓝色和白色子像素的多个单位像素；四色数据转换器，被配置为转换红色，绿色和蓝色的输入数据。每个单位像素分别为红色，绿色，蓝色和白色的数据，分别对应于红色，绿色，蓝色和白色子像素，以及面板驱动器，被配置为在每个累积周期累积每个子像素的数据，将累积的数据存储在存储器中，根据存储在存储器中的白色子像素的累积数据，确定用于校正每个单位像素的颜色的颜色校正模式，根据每个单位像素的白色子像素驱动到决定的颜色校正模式，并选择性地驱动红色，绿色和蓝色子像素。

